



## A Tallysman Accutenna® TW3870E GPS L1/L2 + GLONASS G1/G2 Antenna

The TW3870E employs Tallysman's unique *Accutenna* technology providing dual band GPS L1 & L2, GLONASS G1 & G2, Galileo E1, and BeiDou B1 coverage and is especially designed for precision dual frequency positioning.

The TW3870E features a precision tuned, circular dual feed, stacked patch element. The signals from the two orthogonal feeds are combined in a hybrid combiner, amplified in a wide-band LNA, then band-split for narrow filtering in each band and further amplified prior to recombination at the output.

The TW3870E offers excellent axial ratio and a tightly grouped phase center variation.

The OEM TW3870E is supplied with a standard 60mm diameter circular ground plane, with a coaxial cable terminated with a connector (right angle MCX is shown in the drawing). Mounting holes are provided for attachment to larger ground planes. Custom tuning and ground plane options may be available, depending on purchase level commitment.



TW3870E Dimensions (mm)

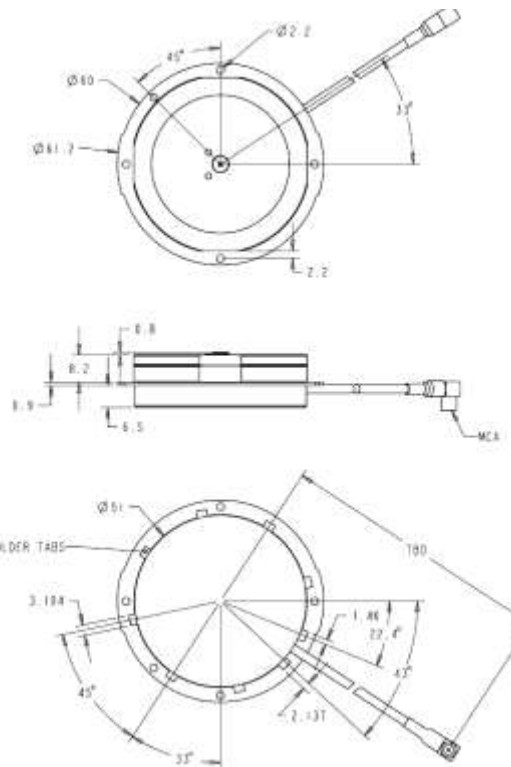

### Applications

- Precision GPS position
- Dual Frequency RTK receivers
- Mission Critical GPS Timing
- Military & Security
- Network Timing and Synchronization

### Features

- Very low Noise Preamp, < 2dB
- Axial ratio: < 2dB typ.
- Tight Phase Center Variation
- LNA Gain 35 dB typ.
- Low current: 20 mA typ.
- ESD circuit protection: 15 KV
- Invariant performance from: +2.5 to 16VDC

### Benefits

- Ideal for L1/L2 RTK surveying systems
- Great multipath rejection
- Increased system accuracy
- Great signal to noise ratio
- IP67 and RoHS compliant



# TW3870E GPS L1 & L2/GLONASS G1 & G2 Antenna

## Specifications (Measured a Vcc = 3V, and Temperature=25°C)

### Antenna

Patch Architecture	Circular, Dual Feed, Dual Stacked Patch
L2 Gain (100mm ground plane), 1227.6-1246MHz	3 dBic Min at Zenith on 100mm Ground Plane
L1 Gain (100mm ground plane), 1575.42MH-1606MHz	4.5 dBic Min at Zenith on 100mm Ground Plane
Axial Ratio, over full bandwidth, both L1 & L2	≤ 2dB typ., 1 dB max. at Zenith, 3dB max at horizon
1dB Bandwidth,	L2: 1227MHz-1250MHz L1: 1570MHz-1606MHz
Polarization	RHCP,

### Electrical

Bandwidth	L2: 1213MHz-1261MHz (Filter bandwidth) L1: 1559MHz-1614MHz (Filter bandwidth)			
Overall LNA Gain	35dB typ, 32 dB min, each of L1 and L2 Bands,			
Gain Variation with Temperature.	3dB max over operational temperature range			
LNA Noise Figure	2dB max at 25°C			
VSWR (at LNA output)	<1.5:1 typ. 1.8:1 max.			
Supply Voltage Range	+2.5 to 16VDC nominal, up to 50mV p-p ripple			
EMI Immunity	50V/Meter, excepting L1+/-100MHz and L2 +/- 100MHz			
Supply Current	20 mA typ. at 25°C, 25mA max at 75°C.			
ESD Circuit protection	15 KV air discharge.			
Out-of-Band Rejection	<b>L1</b>		<b>L2</b>	
	<1450 MHz	>50 dB	<1180 MHz	>40 dB
	<1520 MHz	>30 dB	<1190 MHz	>30 dB
	>1650 MHz	>35 dB	>1284 MHz	>32 dB

### Mechanicals & Environmental

Mechanical Size, Ground Plane	60mm diameter, 0.75mm thick, see mechanical drawing
Operating Temperature Range	-40°C to +85°C
Weight	75 g
Attachment Method	Through hole screws in ground plane
Environmental	RoHS and REACH compliant
Shock	Vertical axis: 50 G, other axes: 30 G
Vibration	3 axis, sweep = 15 min, 10 to 200 Hz sweep: 3 G

### Ordering Information

TW3870E – GPS L1/L2 + GLONASS G1/G2 antenna 33-3870E-xx-yyyy-zz  
 Where xx = connector type, yyyy= cable length in mm and zz is reserved for Tallysman’s use

Please refer to the Ordering Guide (<http://www.tallysman.com/wp-content/uploads/Current-Ordering-Guide.pdf>) for the current and complete list of available connectors.

### Tallysman Wireless Inc

36 Steacie Drive  
 Ottawa ON K2K 2A9 Canada  
 Tel +1 613 591 3131 Fax 613 591 3121  
[sales@tallysman.com](mailto:sales@tallysman.com)

The information provided herein is intended as a guide only and is subject to change without notice. This document is not to be regarded as a guarantee of performance. Tallysman Wireless Inc. hereby disclaims any or all warranties and liabilities of any kind. © 2015 Tallysman Wireless Inc. All rights reserved. Rev 1.4